



THE DESIGNER SERIES

by Joe D'Appolito



DO IT YOURSELF



HOME THEATER

HOME THEATER SYSTEM REQUIREMENTS

Home theater loudspeaker system requirements we are interested in fall into three broad areas: Frequency response, polar response and maximum sound pressure level (SPL). In discussing these requirements we must differentiate between the two forms of home theater sound: the original Dolby Pro Logic™ system and the newer Dolby Digital™ system also referred to as AC-3 or 5.1 channel sound.

In both systems the left, right and center channels cover the full audio frequency range. The Pro Logic surround channel is monaural and limited in frequency to a range of 100Hz to 7kHz. In Dolby Digital all channels are discrete and full range. In addition to the front and surround channels a low-frequency effects (LFE) channel is available for use with subwoofers. Typically, the LFE channel handles frequencies from 20 to 80 Hz, although the upper limit can be as high as 120Hz.

In addition to frequency response, it is also important that all speakers in the system match in the more subtle quality of timbre. All drivers in the Audax home theater system use drivers from the same line and with the same cone material, assuring spectral consistency across all channels.

The front speakers in both systems contain strong directional queues. In Dolby Digital the left and right surround channels also carry independent directional information. Delayed sound arrivals due to reflections off the walls, floor and ceiling can confuse these directional queues. Strong reflections can also alter sonic timbres and make rapid sounds such as speech syllables less clear. In addition to proper placement and room treatment, limiting loudspeaker horizontal and vertical polar response can greatly reduce these reflections and the undesirable effects they produce. It is especially important to limit the vertical and horizontal coverage of the front speakers, concentrating sound within the primary listening and viewing area. Unfortunately we run into a conflict with the requirements for good stereo sound reproduction where broader horizontal coverage is desirable.

In the Audax home theater system the MTM geometry is used in the left and right speakers to limit and narrow vertical polar response. Proper selection of driver size and crossover frequency controls horizontal coverage in all front speakers. An appropriate compromise between stereo and home theater coverage requirements has been made in the design of the left and right speakers. Front speaker polar responses are described in later sections.

There is disagreement on the most desirable polar response pattern for the surround channels. The original THX (Tom Holman eXperiment) home theater specification calls for a dipole pattern. This pattern is quite effective with the monaural surround sound of Dolby Pro-Logic. The dipole produces a "phasey" sound that is difficult to localize, adding to the surround effect.

In AC-3 the left and right surround channels are discrete and contain position specific information. These surround channels will benefit greatly from monopole speakers because they preserve the distinct directional queues present in each AC-3 channel. This is true not only for home theater, but also for the increasing number of music only recordings available in 5.1 channel sound. There is now a new THX specification for home theater installations in smaller rooms, called THX Select. This specification allows monopolar speakers for the surround channels. With proper placement the monopole can be effective in both Dolby Pro-Logic and AC-3 surround sound.

Realistic reproduction of movie sound tracks can require short term SPLs of 105-110dB. All of the individual speakers in the Audax home theater system can produce 105dB within their frequency range in typical size rooms. Their combined output capability easily exceeds 110dB. Sensitivity for the speakers in this system falls in the range of 87-88dB SPL/1w/1m. This translates to minimum amplifier power requirements of 100 per channel.



DO IT YOURSELF



HOME THEATER

SYSTEM SETUP

Loudspeaker Placement

Room reflections and standing waves have a strong effect on frequency response. We have already discussed how we have minimized the effect of room reflections on the higher frequencies through control of loudspeaker polar response. Frequency response below 300Hz or so where all of the speakers are omni-directional is largely controlled by standing wave modes in your room and by loudspeaker and listening position placement relative to those modes.

The smoothest low-frequency response is usually attained using the rule of thirds. That rule states that the speakers and the listener be placed at all one-third points of the room dimensions. For example, consider a rectangular floor plan with front speakers placed along a narrow wall. If the long wall has a length L feet, then the rule of thirds dictates that the front speakers and listening position be placed at distances of $L/3$ and $2L/3$ feet respectively, from the short wall. The L and R speakers should also be placed $1/3$ of the room width from each side wall.

For any particular room fully realizing the rule of thirds may be impractical, but it is often possible to use the rule along one dimension. A typical home theater loudspeaker placement is shown above.

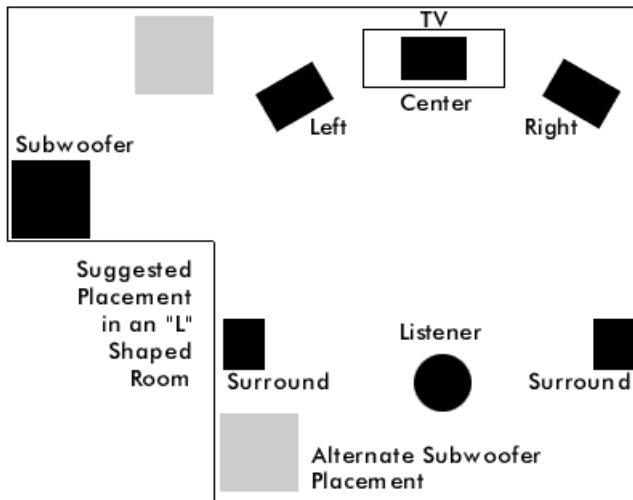
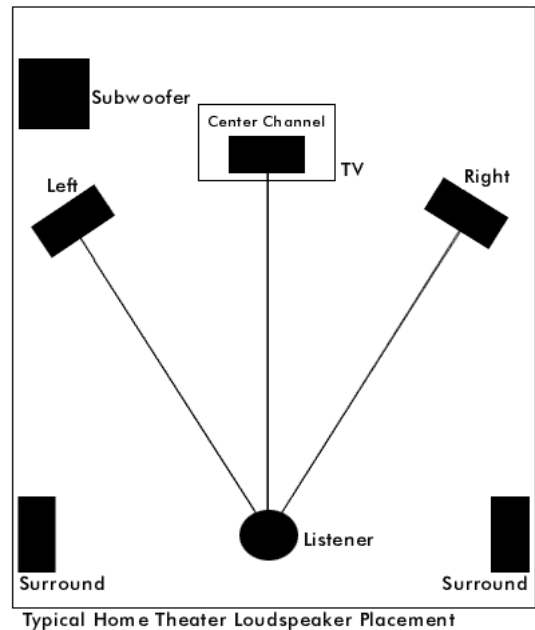

The left, center and right speakers are arranged on a circular arc focused on the primary listening position. This insures that these speakers are all at the same distance from this point. Left and right speaker response is smoothest when placed at least 2-3 feet from any wall. Ideally, the distances to the front and side walls should not be the same.

You can expect to experiment with surround speaker placement. Start with the surrounds placed on the side directly in line with the seating position and slightly above ear height. With Dolby Digital try pointing the speakers directly at the listening position. You may prefer to move the surrounds somewhat behind the listening position.

With Pro Logic, place the surrounds against the wall and try pointing them forward so that you are listening to them well off axis. You may also try moving the surrounds more toward the rear and/or pointing them toward the rear. When pointed to the rear, reversing the surround speaker phase may help. Correct placement with Pro Logic movies may require some experimentation. Be creative!

In order to maximize bass coupling into the room, the subwoofer is generally placed in a corner. If that is not possible, place the subwoofer at the intersection of the floor and one wall. Depending on subwoofer crossover frequency, corner placement may overly excite a particular standing wave mode. This can lead to excessive bass "boom" or one-note bass. In this case, try sliding the subwoofer along one wall by a few feet until the bass response is tamed. The image above left gives a suggested speaker placement for the ever-problematic "L" shaped room.

DO IT YOURSELF

HOME THEATER

THE AUDAX HOME THEATER SYSTEM

The complete Audax Home Theater Loudspeaker system is comprised of; front left, right and center (LCR) speakers, left and right surround speakers and a powered subwoofer. All speakers in the home theater system use drivers from the same line, assuring spectral consistency across all channels.

The left and right channel speakers use the MTM geometry (the D'Appolito configuration) with a pair of 6.5" mid-bass drivers flanking a soft dome tweeter from the Audax Micro Series™ line. This compact tweeter permits closer than normal spacing of the mid-bass drivers resulting in a near ideal vertical polar response pattern for home theater application. The left and right channel speakers are 2-way vented systems with a 4th order acoustic in-phase crossover at 2650Hz. Sensitivity is rated at 88dB/2.83v/1m. Response is within +1.6dB from 100Hz to 20kHz. The low frequency -3dB point is 50Hz. System impedance is 8Ω.

The center channel speaker forms the heart of a home theater system. It defines the focal point for all cinematic action. The center channel speaker must have uniform horizontal polar response over the viewing region both to preserve the spectral balance of spoken dialog and to center the action for off-axis viewers. It should also be essentially a full range system.

To this end, the center channel is a 3-way vented speaker. A Micro Series™ tweeter and 5.25" mid-bass driver are vertically aligned and placed on the centerline of the speaker baffle to handle the high frequencies and the midrange. A pair of 6.5" woofers flanks the tweeter and midrange drivers. Crossovers occur at 400Hz and 3.5kHz. On-axis frequency response is within +1.6dB from 100Hz to 20kHz. The low frequency -3dB point is 55Hz and sensitivity is 87.5dB/2.83v/1m. At typical viewing angles within +15° off the on-axis position, response changes less than 1dB over the full frequency range.

Aiming the system toward AC-3, the monopole radiation pattern was chosen for the surround speakers. The surround speaker uses the same 6.5" mid-bass driver and tweeter used in the LCR channels. This surround speaker is a closed-box 2-way design with a 4th order in-phase acoustic crossover at 3kHz. Response is within +1.5dB from 100Hz to 20kHz. The -3dB point is 85Hz and sensitivity is rated at 88dB/2.83v/1m.

The powered subwoofer uses 12" long throw woofer in a vented enclosure to produce a -3dB point of 30Hz. An integral 150-watt amplifier sums the left and right channels to supply a mono signal to the woofer. There is a 12db/octave electronic low-pass filter with a continuously variable crossover frequency ranging from 40 to 200Hz. A direct input bypasses this crossover to accept input from the LFE channel. A single subwoofer will produce 105dB SPL into a half-space at 26Hz. Corner placement and room gain can add 6-10dB more to this figure.



DO IT YOURSELF



HOME THEATER

CONSTRUCTION TIPS

Enclosure

Readymade enclosures are available from a list of suppliers presented elsewhere in this brochure. For those of you who prefer to build the enclosures, we generally recommend medium density fiberboard (MDF) or particleboard for loudspeaker boxes. Both of these materials have relatively high internal damping. The enclosures can be painted or veneered to according to decorating needs. Furniture grade plywood (no internal voids) can also be used, but may require additional bracing to reduce cabinet wall vibrations. Minimum wall thickness should be $\frac{3}{4}$ ". 1" is recommended for all front baffles and the subwoofer cabinet.

Cut all panels to size and make all holes before assembly. Flush mount all drivers to eliminate diffraction caused by the raised edge of the driver flange. A router will be needed to rabbet driver flanges flush with the baffle. (The TM025F1 micro tweeter does not require flush mounting.) Use weather stripping available at hardware stores to seal the joint between driver flanges and the speaker baffle. A tight seal is especially critical in vented enclosures.

Butt joints are shown on all enclosure drawings. This is the simplest joint and is adequate for speaker box construction. Those among you with greater wood working skills and the appropriate tools can certainly use more sophisticated joints. Glue all joints with yellow carpenter's glue. Once the glue is set, apply a silicone sealer or caulk to all inside seams and joints, including terminal cups and ports, to seal the enclosure.

Grille details are not included with the enclosure drawings. Grilles are not recommended unless required for esthetic purposes or to protect drivers from curious children or animals. The grilles supplied with most readymade enclosures have bulky wooden frames that produce response irregularities due to edge diffraction. These grilles are for cosmetic purposes only. Wire frame grilles can be made that produce very little diffraction. The wire frame is mounted to the front baffle with standoffs and covered with an acoustically transparent cloth or reticulated open cell foam. The grille supports the grille covering at its outer edges only.

Crossover

Don't skimp on crossover components. High quality Mylar or metalized polypropylene capacitors with at least a 100V rating should be used in all crossovers. Air-core inductors are recommended for all coils except for the woofer crossover coil in the center channel speaker. Because of its large value, a high quality ferrite or iron core coil is specified here. Wire size and resistance are specified for each coil. In general you should avoid the urge to increase wire size for lower resistance. In most cases, the coil resistance is critical to controlling crossover Q. Lower resistance can lead to undesirable crossover response peaking.

Crossover components should be firmly mounted to a $\frac{1}{4}$ " Masonite™ or plywood board with silicone glue or better still "liquid nails" available in most hardware stores. High-pass and low-pass sections should be placed on separate boards and placed opposite walls of the enclosure. You do not need to be concerned about the effect of driver magnetic fields since all woofers in this project are extremely well shielded. All resistors should have at least a 10 watt power rating.

Suggested component layouts for each crossover network are given in the text. You may have to modify the suggested configuration to accommodate component sizes or shapes that differ from those we used to develop the layouts.

TIP: To improve the acoustic sound, line all speakers with 2" acoustic foam or similar material. Lightly pack the Front and Centre speakers with long hair wool wadding and tightly pack the rear speakers with long hair wool wadding.

Home theater systems are gaining in popularity every day. Unfortunately, the need for five high-quality loudspeakers plus a subwoofer or two can take the cost of these systems out of the price range of many who would otherwise enjoy them. Our newly developed line of lower-cost fully shielded drivers forms the basis for the Designer Series of home theater loudspeaker system. Building on the foundation of this new driver line Joe D'Appolito of Audio and Acoustics, Ltd. has designed a complete home theater speaker system for us. The full specifications for the system, including cabinet drawings, crossover schematics, parts lists and typical performance curves are included in these pages.

The focus of this kit design is our new PC (Polymer Chassis) series range of drivers. Our R&D team has selected the highest grade of pure polymer for the basis of this concept. Each chassis shape and profile was analyzed and dissected by our CAD software to create the best ratio between the mechanical properties, weight to stiffness, material flow and molding cycle time. The end results are the PC drivers deliver increased efficiency due to the non-magnetic properties of the polymer, improve the stray flux cancellation and offer superior environmental strength.

In addition, we offer 3 cone materials to choose from: Patented HD-A, Coated Paper and Paper. We have selected our patented HD-A cone technology for this kit project. Light, stiff and well damped make the HD-A cone a great choice for the demands of the home theater market. In depth detail and imaging allow you to enjoy the theater sound quality in your home



THE LEFT & RIGHT CHANNEL SPEAKERS

The left and right channel speakers are two-way MTM designs using a pair of Audax AP170ZO 6.5" HD-A cone woofers and a TM025F1 textile dome tweeter from the Micro Series line. This tweeter employs a high-energy neodymium magnet and a ferrofluid cooled voice coil for increased power handling ability. The vented enclosure has been computer optimized to maximize the power handling and low frequency extension of the woofer pair. The result of this optimization is a low frequency -3dB point of 50Hz with a 105db SPL capability at any frequency above the -3dB point.

Crossover

The woofer and tweeter crossover have been computer optimized to provide an overall fourth-order, in-phase acoustic crossover at 2650Hz. Driver impedance and frequency response are fully accounted for in the optimization process.

The woofer crossover consists of a second-order low-pass filter realized with L1 and C1 plus a controlled-Q parallel resonant trap made up of R1, C2 and L2. The trap suppresses a peak in the woofer response at 3600Hz and provides additional roll off of woofer frequency response above crossover. The woofers are connected in series to better match the sensitivity of the tweeter. Resistors R2 and R3 equalize power sharing between the two woofers. 16-gauge wire is called out for L1. Although not necessary, 14-gauge wire may be used to gain a few tenths more dB in sensitivity.

The tweeter crossover consists of a third-order electrical network made up of C3, C4 and L3. L3 is made with 18-gauge wire. Do not use a larger wire size. The resistance of the coil controls crossover Q. A larger size wire will produce peaking of the tweeter response at crossover. Resistors R4 and R5 form an L-pad that attenuates tweeter response just enough to match the sensitivity of the series woofer pair. Capacitor C5 rolls off a high-frequency rise in tweeter response to produce an overall flat response. Notice that all drivers are connected with positive polarity.



Crossover Parts List (ME Part No. in brackets)

L1 = 1.8mH, 0.43Ω, #16AWG (XL1.8/1.6/2)

L2 = 0.15mH, 0.17Ω, #18AWG (XL0.15/1/1a)

L3 = 0.27mH, 0.24Ω, #18AWG (XL0.27/1/1a)

C1 = 8mfd [4.7mfd & 3.3mfd in parallel]

(PP4.7 & PP3.3)

C2 = 13mfd [12mfd & 1mfd in parallel]

(PPA12 & PPA1)

C3 = 6.8mfd (PP6.8)

C4 = 15mfd [10mfd & 4.7mfd in parallel]

(PP10 & PP4.7)

C5 = 2mfd [2.2mfd] (PP2.2)

R1 = 18Ω, 10watts (XR18/10)

R2, R3 = 10Ω, 25watts * (XR3.3/10)

R4 = 5Ω, 10watts (XR4.7/10)

R5 = 15Ω, 10watts (XR15/10)

* Replace with 3 x 3.3Ω, 10watts

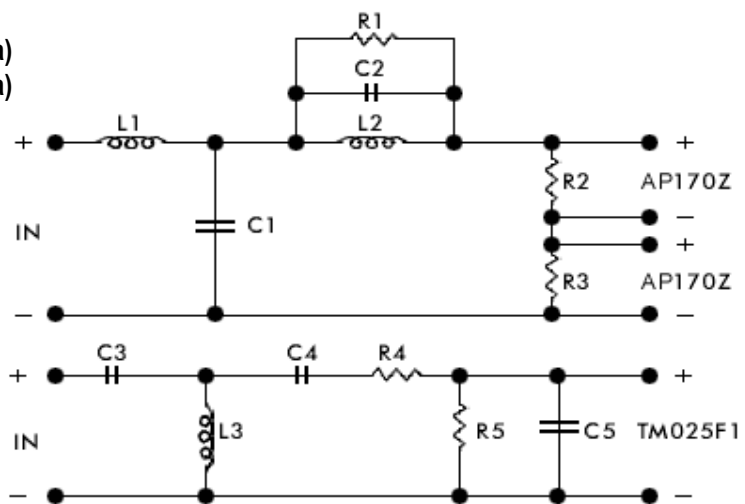

Left/Right Speaker Crossover Network Diagram

DO IT YOURSELF

HOME THEATER

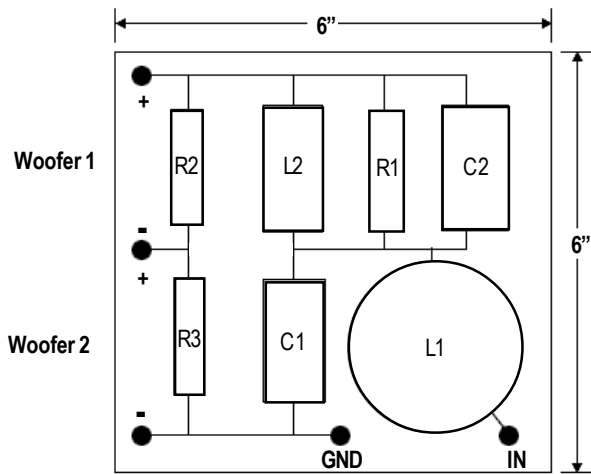

Left / Right Speaker Woofer Crossover Layout
(2 x Boards)

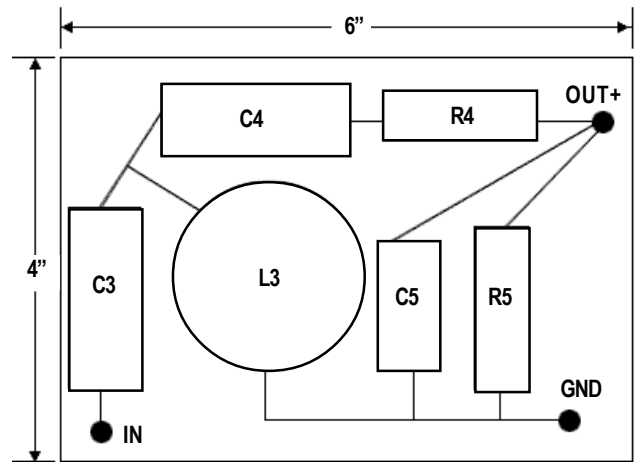

Left / Right Speaker Tweeter Crossover Layout
(2 x Boards)

The enclosure has a net internal volume of 30 liters. A 3" ID port tube 5 1/4" long tunes the enclosure to 49Hz. The interior port opening is supported by an 8" x 8" piece of 1" MDF. This piece forms a baffle that linearizes port volume velocity at high SPLs and also serves to brace the enclosure sides against vibration. The port baffle should fit snugly between the enclosure sides and be glued in place. The enclosure sides can be drawn tightly to the interior port baffle with coarse-thread deck screws. Both ends of the port tube have a 1/2" quarter round applied with a quarter rounding router bit to further smooth airflow at the port openings.

Left / Right Channel Enclosures (1 of 2)

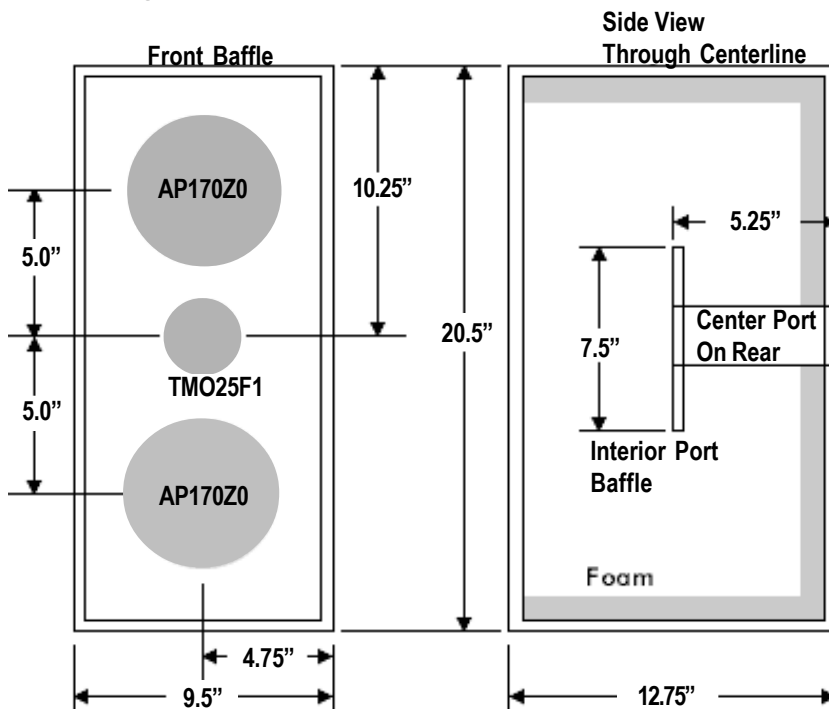

The enclosure is internally damped with 2" "egg-crate" acoustic foam placed on the top, bottom, rear and one side of the enclosure. The foam can be glued in place with rug cement available at hardware stores. If acoustic foam is not available, egg-crate foam mattress pad is an acceptable substitute.

*Note: Tweeter mounting hole is 2" ID. Tweeter is mounted flush on front baffle. Top, bottom, sides and rear lined with 2" egg-crate acoustic foam.
(Drawing is not to scale)*

DO IT YOURSELF

HOME THEATER

THE CENTER CHANNEL SPEAKER

The center channel speaker is designed to produce uniform frequency response over the primary listening area. A Micro Series tweeter and AP130ZO 5.25" HD-A coned mid-bass driver are vertically aligned and placed on the centerline of the speaker baffle to handle the high frequencies and midrange. A pair of 6.5" woofers flanks the tweeter and midrange drivers. The woofer enclosure is vented and tuned to the same QB3 alignment used in the left and right channel speakers. In typical listening rooms, the center channel speaker can produce 105dB SPL at any frequency above 50Hz.



Center channel on-axis frequency response is within +1.5dB from 100Hz to 20kHz. The low frequency -3dB point is 50Hz and sensitivity is 87.5dB/2.83v/1m. Crossovers are seen to occur at 400Hz and 3.5kHz. The response of the woofer pair, midrange and tweeter are each down 6dB at their respective crossover frequencies indicating that the drivers are in phase at crossover.

Impedance is above 7.5Ω throughout most of the low-frequency range. The minimum impedance of 5Ω occurs at 4.5kHz. This is frequency is high enough to be of little concern. Phase angle lies within +40° over the entire frequency range. This is an easy load for typical multi-channel home theater receivers.

Crossover

The low-pass filter comprised of L1 and C1 constitutes a second-order electrical network. Similar to the L/R speaker, resistors R1 and R2 equalize power sharing between the two woofers. Notice that the woofers are connected in reverse polarity as required for 2nd-order in-phase crossovers. Because of its large value, an iron core or ferrite core coil can be used for L1. The specified DCR for L1 is 0.48Ω. We have experienced no undesirable effects on performance using the cored coil. The purest among you can replace L1 with a 12-gauge air-core coil.

The midrange crossover has 2nd-order high-pass and 3rd-order low-pass characteristics. The topology is a bit unusual in that it does not resemble the traditional high-pass/low-pass cascade. Rather the topology is derived from a low-pass to band pass transformation. You can think of the 400Hz high-pass filter as being made up of L2, C3 and R5. This combination provides a 2nd-order response to compliment the 2nd-order woofer roll off. R5 controls the Q of the 2nd-order response. C2, L3 and C7 make up a 3rd-order low-pass. This electrical filter combines with the natural response of the midrange to produce an overall 4th-order in-phase high-pass response at 3500Hz.

The tweeter high-pass filter is also a 3rd-order electrical filter. Again, this filter combines with the tweeter response to yield an overall 4th-order in-phase response. The high-frequency roll off capacitor used in the L/R speaker crossover (C5 of Fig. 7) is not needed here since the 3500Hz-crossover frequency is above the point where the tweeter response begins to rise.

Crossover Parts List (ME Part No. in brackets)

L1 = 6.8mH, 0.48Ω, (XL6.8/1.8/C)

ferrite or iron core

(#12AWG air core for the purist)

L2 = 1.2mH, 0.34Ω, #16AWG (XL1.2/1.6/2)

L3 = 2.7mH, 0.53Ω, #16AWG* (XL2.7/1.6/2)

L4 = 0.27mH, 0.24Ω, #18AWG (XL0.27/1/1a)

C1 = 62mfd [6x10mfd & 2.2mfd in parallel] (PP10 & PP2.2)

C2 = 24mfd [2x12mfd in parallel] (PPA12)

C3 = 10mfd (PP10)

C4 = 82mfd [8x10mfd & 2.2mfd in parallel] (PP10 & PP2.2)

C5 = 4.7mfd (PP4.7)

C6 = 8 mfd [4.7mfd & 3.3mfd in parallel] (PP4.7 & PP3.3)

R1, R2 = 10Ω, 25watts * (XR3.3/10)

R3 = 8Ω, 10watts (XR8.2/10)

R4 = 15Ω, 10watts (XR15/10)

R5 = 2Ω, 10watts (XR2.2/10)

* Replace with 3 x 3.3Ω, 10watts

DO IT YOURSELF

HOME THEATER

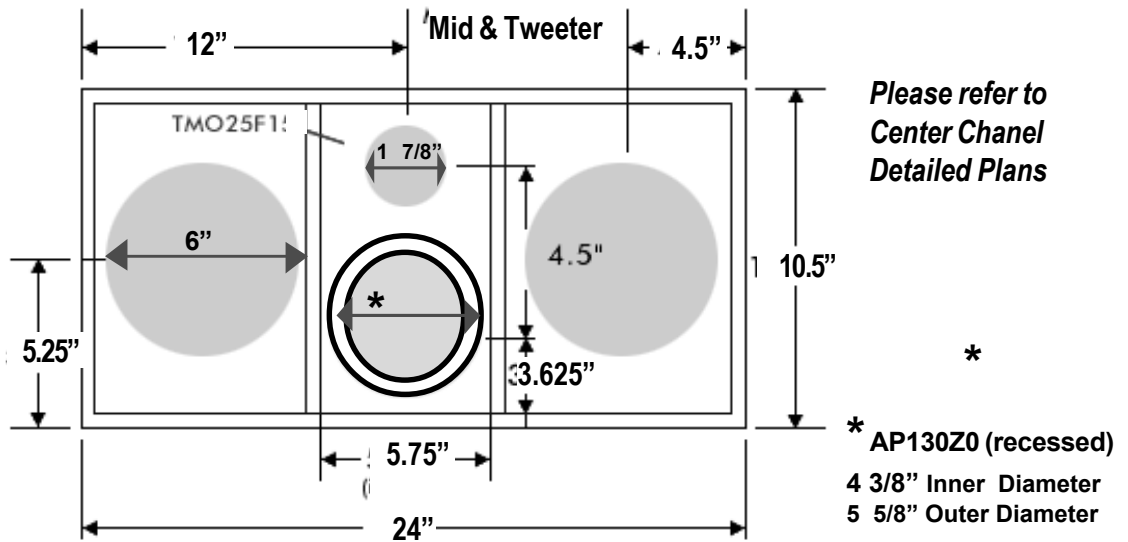

Audax Center Channel Front View

All material 3/4" MDF except front baffle. Front baffle 1" MDF, edges rounded.
(Drawing not to scale)

The bass response alignment is the same as that used in the L/R speakers. That is, the internal volume of 30 liters occupied by the woofers is tuned to 49Hz. However, the 3" ID port used in the L/R speakers is replaced with two 2" ID ports 5" in length. The center channel enclosure contains a 6-liter sub enclosure housing the 5.25" midrange driver and tweeter. The rear wall of the sub enclosure is lined with 2" acoustic foam and filled with lightly compressed hi-loft Dacron™ pillow stuffing. The woofer volume is damped with 2" acoustic foam applied to the rear, sides and top or bottom (not both) of the enclosure.

Audax Center Channel Top View

Line rear, sides top, or bottom (not both) with 2" acoustic foam. Line rear of mid/tweeter enclosure with 2" acoustic foam. Fill sub-enclosure with lightly compressed high loft Dacron or long hair wool wadding.

All material 3/4" MDF except front baffle. Front baffle 1" MDF. Drawing not to scale.

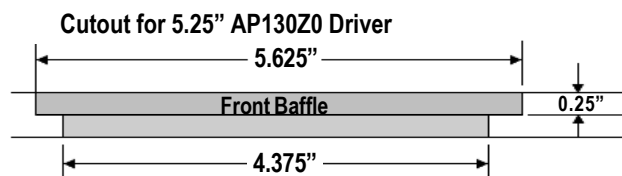
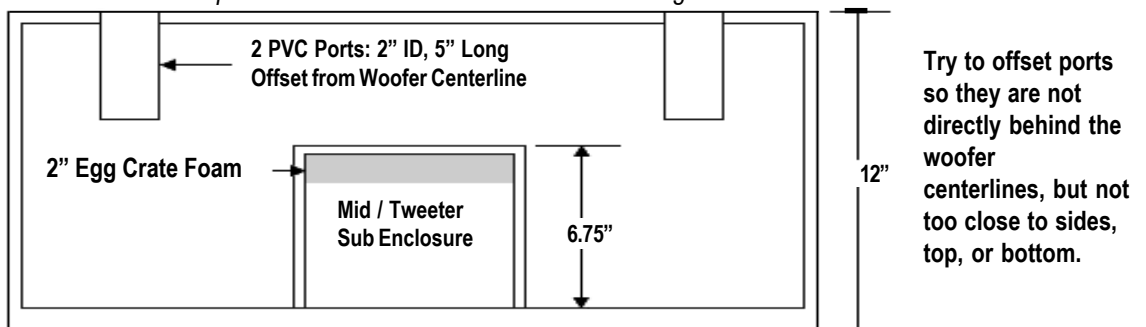

Center Speaker Crossover Network Diagram

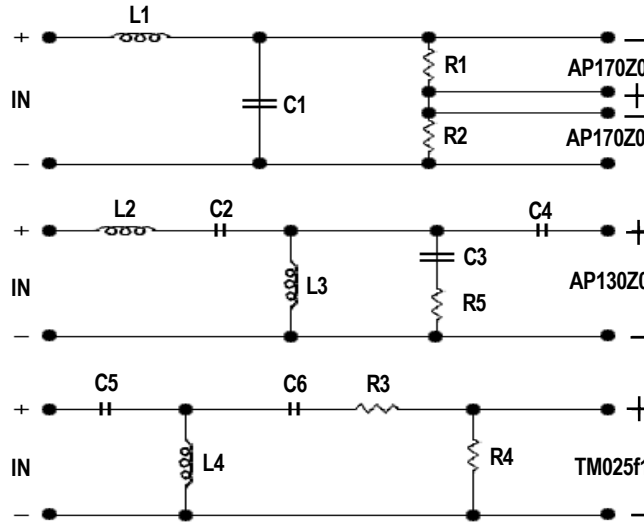

Crossover Layout For Center Channel Woofer, Midrange and Tweeter

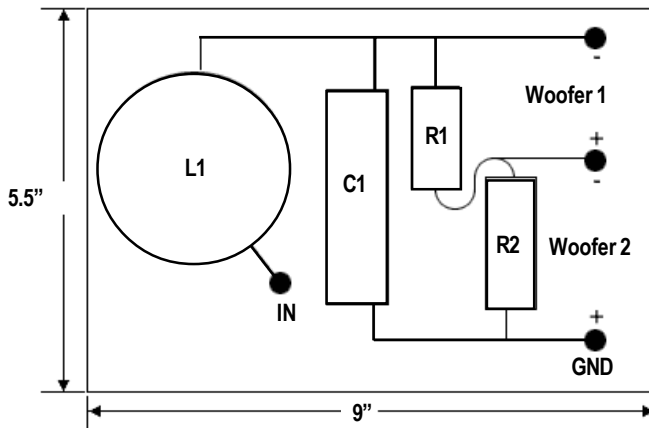

Center Channel Woofer Crossover Layout
(Note: Woofer polarity is reversed.)
(1 x Board)

IMPORTANT NOTE: If the Center Kit Option is being used (KDSC-OP) using Premium Inductor XL6.8/2.98/C new board dimensions apply. Board size 6.5" x 10" The board will not fit through the speaker cutout. Because the premium Inductor is so large the Inductor should be mounted separately and independantly from the Center Woofer Crossover board, and mounted inside the cabinet before the rear panel is fitted.

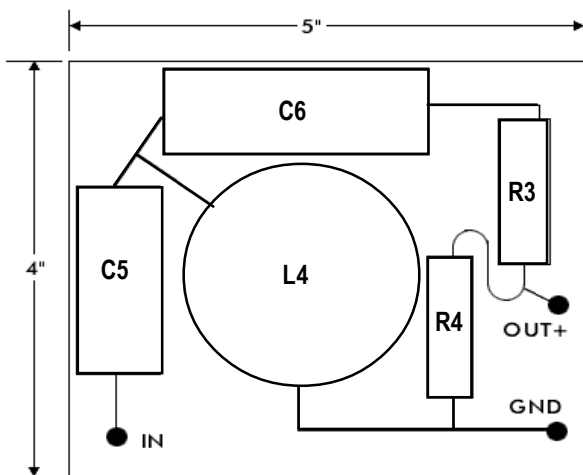

Crossover Layout for Center Channel Tweeter
(1 x Board)

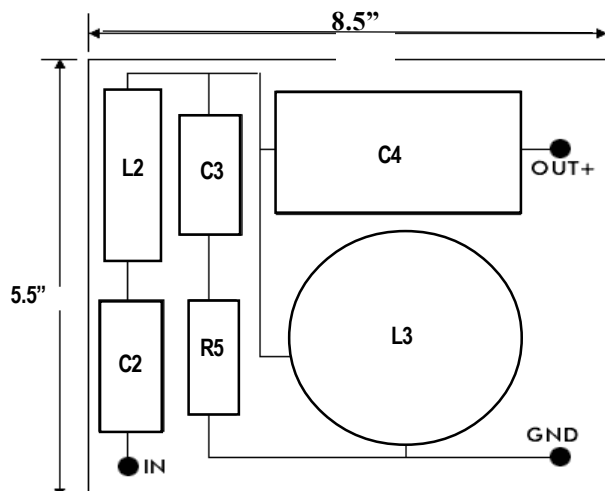

Crossover Layout for Center Channel Midrange
(1 x Board)

DO IT YOURSELF

HOME THEATER

THE SURROUND SPEAKER

The surround speaker is a closed-box design using the same 6.5" woofer and Micro Tweeter used in the L/R and center channel speakers. Response is flat within +1.6dB from 100Hz to 20kHz. The half-space -3dB point is at 85Hz. Bass response will extend below this frequency when the surround speaker is placed against a wall. Sensitivity averages 88db/2.83v/1m. A 4th-order acoustic crossover occurs at 3kHz.

The woofer crossover network is 2nd-order electrical, but it combines with the natural roll off of the woofer to produce an overall 4th-order acoustic response. The tweeter also achieves a 4th-order characteristic with a 2nd-order electrical filter. Crossover component values are given in Table 3. All coils are air-core.



Crossover Parts List (ME Part No. in brackets)

L1 = 1.5mH, 0.4Ω, #16AWG (XL1.5/1.6/2)

L2 = 0.22mH, 0.2Ω, #18AWG (XL0.22/1/1a)

C1 = 11mfd [10mfd & 1 mfd in parallel] (PP10 & PPA1)

C2 = 8mfd [4.7mfd & 3.3mfd] (PP4.7 & PP3.3)

R1 = 5Ω, 10 watts (XR5/10)

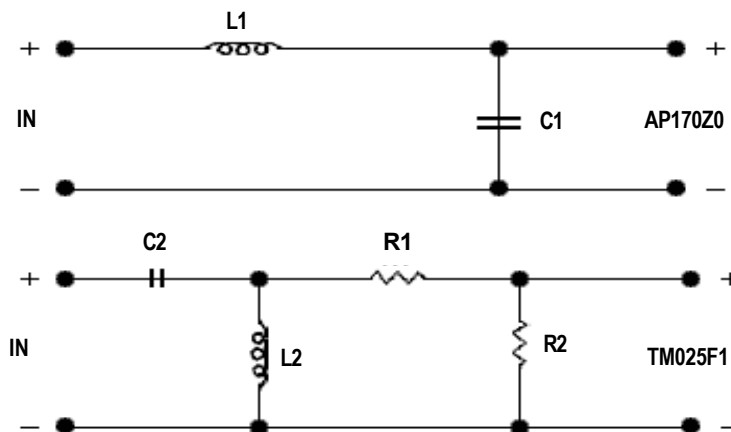

Surround Speaker Crossover Network

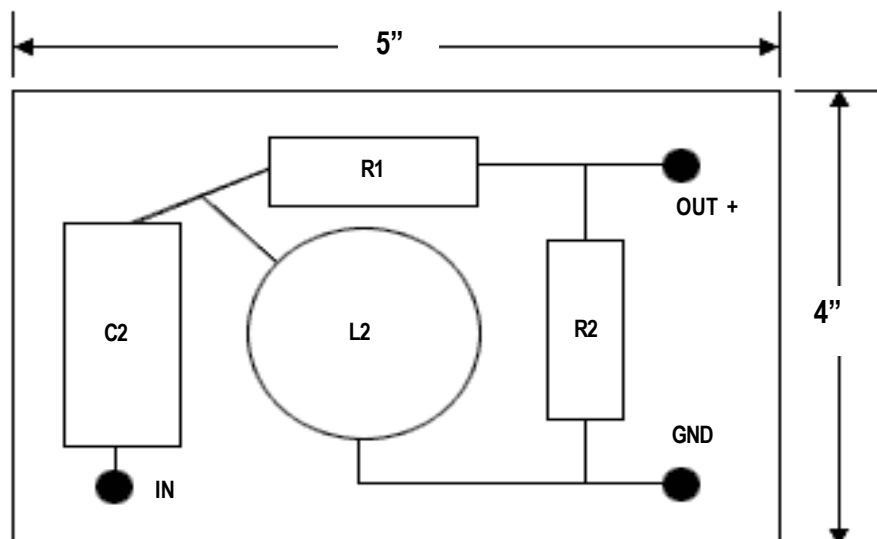

Surround Speaker Tweeter Crossover Layout (2 x Boards)

Surround Speaker Crossover Layout (2 x Boards)

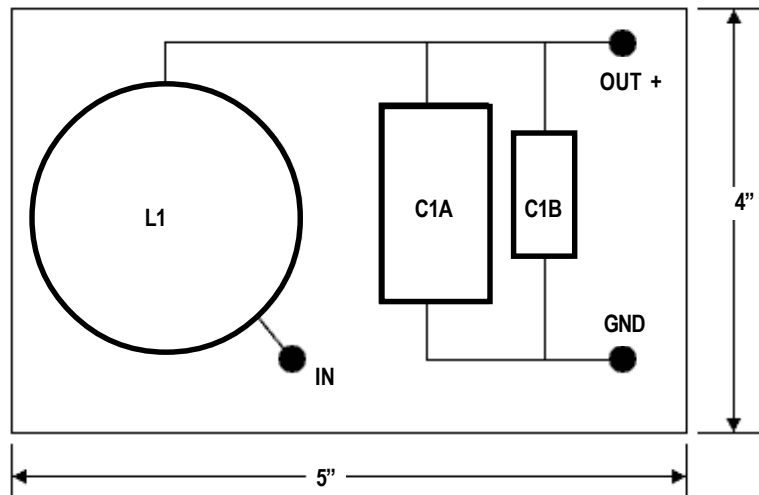

Line sides and rear with 2" egg-crate acoustic foam or similar product.

Audax Surround Speaker Enclosure

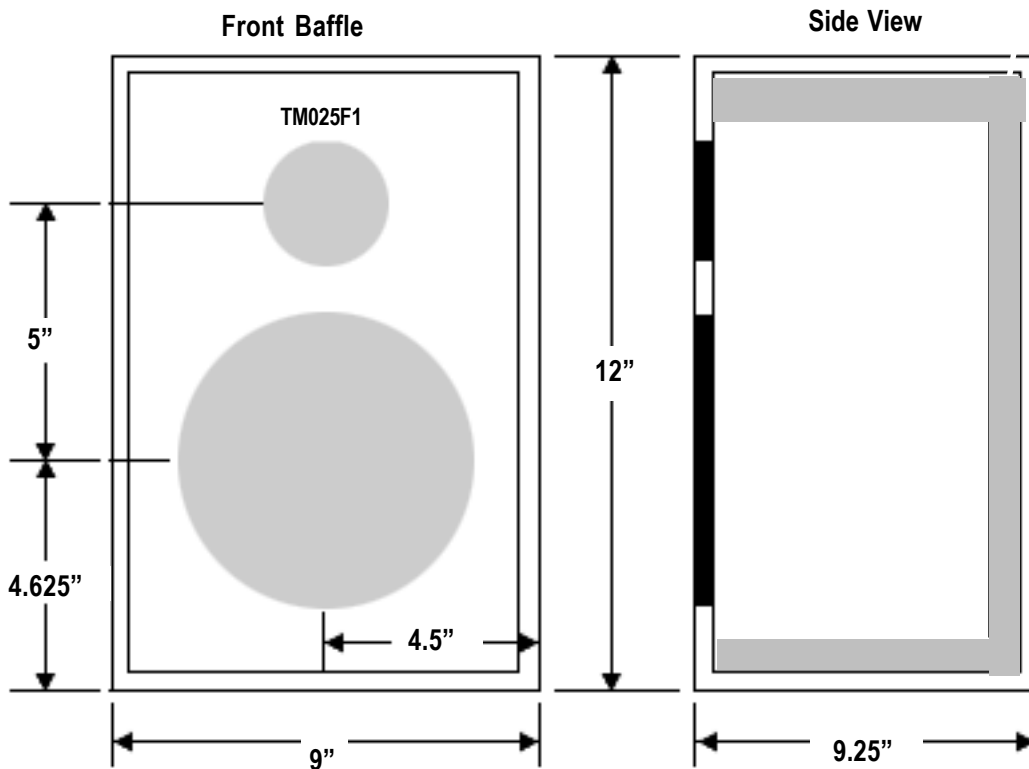

1. Front Baffle is 1" MDF, 1/2" quarter round on front baffle.
2. Top, bottom, and sides are 3/4" MDF, mount terminal block on rear.
3. Mounting holes for tweeter and 6.5" woofer are given on earlier drawings.

DO IT YOURSELF

HOME THEATER

THE POWERED SUBWOOFER

The subwoofer uses an Audax HT300Z long-throw 12" woofer in a vented enclosure. An extended bass shelf alignment was selected for maximum bass extension. The net internal volume of 80 liters is tuned to 30Hz. The subwoofer's half-space -3dB frequency is 30Hz. A single subwoofer will produce 105dB SPL into a half-space at 30Hz. Corner placement and room gain can add 6-10dB more to this figure and extend useful output below 25Hz.

ME Technologies do not supply or keep in stock the subwoofer power amplifier. If fitting a power subwoofer amplifier, allow for cutout dimensions on the back panel.

Enclosure (Subwoofer 1)

The cabinet is a perfect cube. 1" MDF is used for all walls. 2" x 3" internal bracing stiffens the walls. A 4" ID PVC pipe 7³/₄" long tunes the enclosure to 30Hz. A 7" x 7" internal baffle attached to the side and bottom of the enclosure supports the port tube at its interior opening. Both ends of the port are contoured with a 1/2" quarter round. The woofer amplifier is mounted in an 8" x 8" cutout on the rear. The size of this cutout may change depending upon the amplifier that you choose. The rear, sides, top and bottom of the enclosure are lined with 2" acoustic foam.

Subwoofer 1 (revised for HT300Z2)

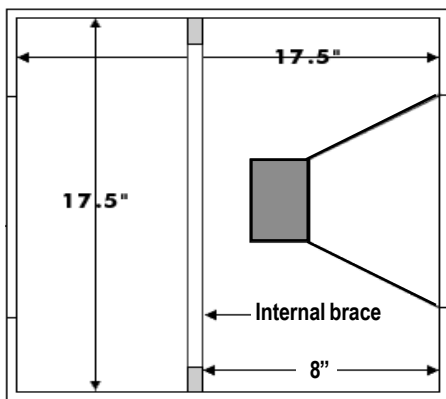

- Notes:
- 1) Enclosure is a cube, interior dimensions (17.5" x 17.5")
 - 2) All material is 1" MDF
 - 3) Line rear, top, bottom and sides with 2" acoustic foam.
 - 4) Put 8"x8" cutout for subwoofer amplifier on rear panel.
 - 5) Port is 4" ID PVC pipe 7.7.5" long.
 - 6) Place appropriate feet or spikes on bottom.
 - 7) 2"x3" brace across all sides.

View of Woofer Baffle

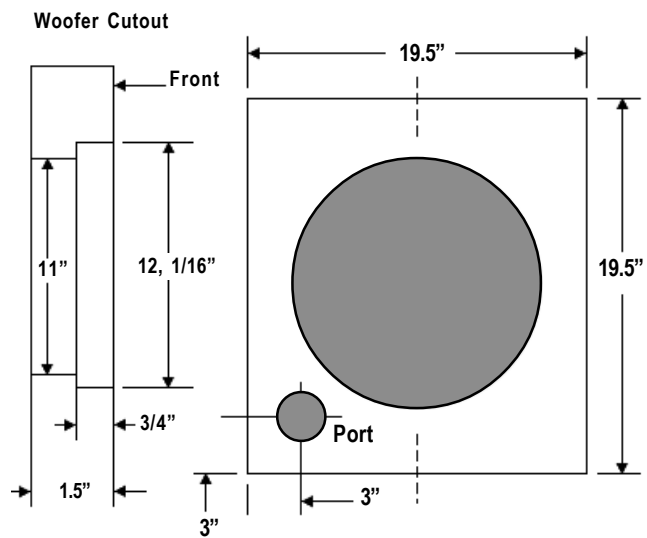

- Notes:
- 1) Woofers are mounted face to face. Both flanges fit into cutout. Cutout keeps woofer flanges aligned. Woofer are screwed in together with gaskets slightly compressed.
 - 2) Port is 4" ID PVC pipe 9" long

One possible version of Audax Subwoofer (view through centerline)

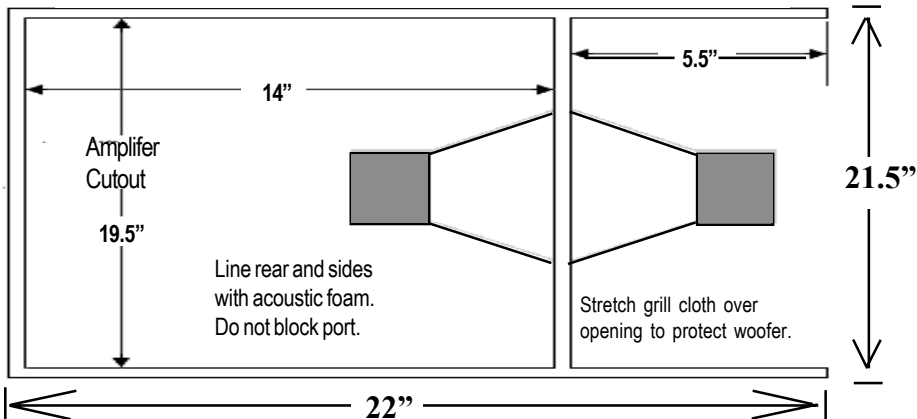

- Notes:
- 1) All dimensions are interior dimensions. Exterior dimensions will depend on thickness of stock used.
 - 2) 8"x8" cutout on rear to mount amplifier.