

Operating Instructions

MC Type (Dual Moving Coil) Stereo Cartridge AT-OC9/III MC

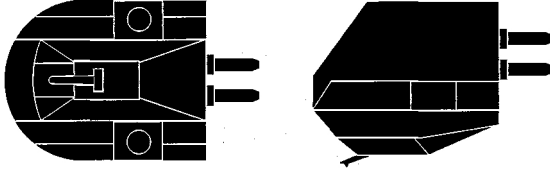

Caution

This stereo cartridge was designed with painstaking attention given to safety, but trouble may occur if it is used incorrectly. Heed the following precautions to prevent accidents from occurring.

- Keep the cartridge out of the reach of small children. Failure to heed this precaution may result in accidents or malfunctioning.
- Keep the plastic bag provided with the cartridge out of the reach of small children and away from flames. Failure to heed this precaution may result in accidents or a fire.
- Do not put this cartridge in a location where it will be exposed to direct sunlight, near heating appliances or in places with a high temperature and high humidity or with high concentrations of dust. Failure to heed this precaution may result in malfunctioning or trouble.
- Do not touch the cartridge's cantilever fulcrum. Failure to heed this precaution may result in malfunctioning.
- Do not attempt to disassemble or remodel the cartridge. Failure to heed this precaution may result in malfunctioning.
- Do not subject the cartridge to strong impact. Failure to heed this precaution may result in malfunctioning.

Features

● Flagship model embodying the highest sound quality ever in the series

The AT-OC9, launched on the market in 1987, was the original cartridge model from which the AT-OC9/III evolved. Over the years, the AT-OC series has undergone a number of model changes both inside and outside Japan, and it has continued to be a bestseller for us for over twenty years. While drawing on the basic design of the AT-OC9ML/II which has been available exclusively on overseas markets and which has received high critical acclaim, we adopted a fresh approach that called for us to review the stylus tip, cantilever, magnetic circuit parts, damper and other aspects in order to track down and embody the highest sound quality. It is this approach which has given birth to our new model. Our new stereo cartridge is designed to enable you to enjoy to the full a sound quality packed with information and a rich expressiveness of sound where the music reaches out to you from the depths of silence.

● Special line contact stylus and solid boron cantilever with a 0.26 mm diameter

The cartridge features a special line contact stylus with a 40µm x 7µm curvature radius at the stylus tip. This not only ensures that the music signals engraved in the analog records will be read out completely but also it gives expression to the highest dynamic compliance of the series. By firmly embedding this line contact stylus in a solid boron cantilever with its 0.26 mm diameter and by bonding it in place, the music signals read by the tip of the stylus are transmitted reliably to the power-generating coils.



● Neodymium magnet and permendur yoke have drastically increased the magnetic energy

Employed as the magnet is a neodymium magnet with a maximum energy product BHmax of 50[kJ/m³] while used as the yoke is a permendur yoke with a high saturation flux density and excellent magnetic materials. Together, they further boost the magnetic field concentrated in the coil gap area.

● PCOCC used for coils and terminal pins

PCOCC does not give rise to crystalline interfacing in the transmission direction so audiophiles can enjoy pure transmissions.

PCOCC

PCOCC = Pure Copper by Ohno Continuous Casting process
(Mono-crystalline high-purity oxygen-free copper)

● Dual moving coil with high separation and wide response

Our unique moving coil type cartridge has a basic structure where one cylindrical coil is used for the left channel and another is used for the right channel. This structure by which power is generated independently for the left and right channels physically provides outstanding separation characteristics. The leakage of signals from one channel into the other exerts a decisive influence on the stereo expanse as well as on the sound quality. This is because this leakage is tantamount to creating irregular cross modulation. The reason why the dual moving coil system delivers such a clear and finely delineated sound quality is no doubt due to the system's naturally excellent separation.

The AT-OC9/III adopts a reverse V-shaped formation for the two left and right coils to reduce the vibration mass as seen from the stylus tip and minimize the unnecessary movement of the coils to further diminish the distortion.

● VC mold for minimizing unnecessary vibration

The VC mold that holds the coils in place is made of a hard synthetic resin which is combined with potassium titanate for increased strength and rigidity.

● Rugged body dedicated to achieving a design with increased rigidity

Using a precision-crafted sturdy aluminum alloy as the base, the body's structure is made of hard resin to hold down parasitic resonance to the minimum. This minimizes undesirable vibration, and the bottom of the body is plated to achieve greater rigidity and an improved signal-to-noise ratio.

● High-sound-quality brass mounting screw

A brass mounting screw is provided to attach the cartridge to the shell. It is optimally suited to the high sound quality of the cartridge itself.

How to remove the cartridge from its case

- (1) Remove the top transparent case, and install the protector inside the mount onto the cartridge.
- (2) Push the orange button into the back position to release the lock.
- (3) Take hold of the side of the cartridge, and draw it out in the direction shown by the arrow in the diagram.
- (4) Using the flat-head screwdriver provided, remove the cartridge from the dummy shell. When doing this, take sufficient care not to damage the tip of the cartridge stylus.

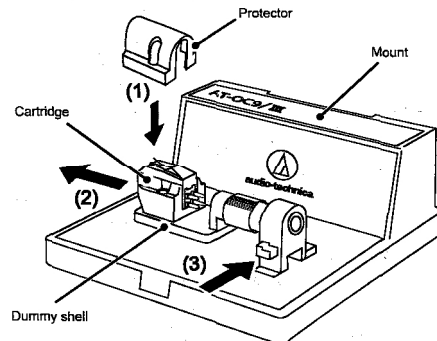

Caution When storing the cartridge in its case, first be absolutely sure to mount the protector and insert the dummy shell or headshell, and then be absolutely sure to push the orange button to the front position to engage the lock. Unless the lock is engaged, the cartridge will fall out and be damaged.

Operation

* The stylus section is extremely fragile. Exercise sufficient care in handling it.

(1) Mount the cartridge onto the headshell.

Install the protector to ensure that the cantilever fulcrum will not be damaged. (The protector is contained inside the mount of the packaging case.) Loosely secure the screws. Use the heaviest possible headshell.

(2) While noting the polarities of the output terminals, insert the lead wire tips.

The figure below shows the layout of the headshell lead wires of a universal tonearm. Connect the lead wires with the same color to the output terminals of the cartridge.

If the lead wire tips are loose, pinch them a little, and then insert. Under no circumstances must any heat such as that accompanying soldering operations be applied to the output terminals.

The PCOCC wires provided are the best match for the lead wires. When the connections have been completed, remove the protector.

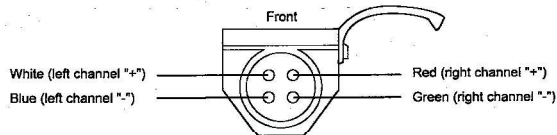

Layout of shell lead wires as seen from the front (for a universal tonearm)

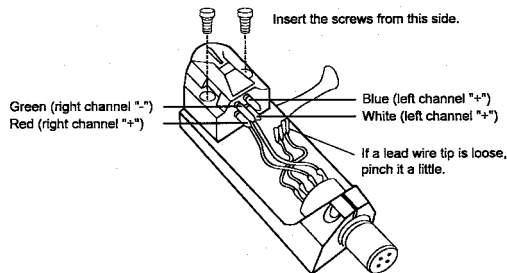

* The figure shows the headshell with the protector removed so that it is easier to see where the connections are to be made.

(3) Decide on the exact position where the cartridge is to be mounted.

(Overhang adjustment)

Adjust the overhang by following the instructions in the record player's manual.

If the procedure is not clear, adjust the stylus tip position to the cartridge which originally came attached to the record player. (See figure below)

The sound quality will suffer if the difference is great so the overhang should be adjusted ideally to within +/-1 mm of that of the original cartridge.

Cartridge provided with arm AT-OC9/III

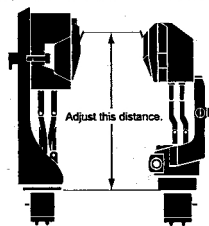

* After completing the adjustment, tighten up the screws evenly at the left and right.

(4) Adjust the tracking force. The standard level is 2.0 g.

The appropriate tracking force of this cartridge is in the range of 1.8 to 2.2 g (standard level: 2.0 g).

Normally, it is set to 2.0 g.

Depending on the air temperature, condition of the records to be played or other operating conditions (such as heavy vibration), adjust the tracking force, but ensure that it is adjusted to the level within the applicable range.

(5) When it is possible to adjust the arm height:

Adjust the height so that the bottom of the headshell and the surface of the records are made parallel as seen from the side. If the arm is not positioned at the right height, the cartridge body may touch the records and/or the sound quality may suffer.

(6) A transformer, head amplifier or discrete phono equalizer is required to make the connection with the amplifier.

If the amplifier comes with a PHONO input (MC position) setting, it can be used as is. However, to make the most of the cartridge's sound quality, use of a step-up transformer (purchased separately), head amplifier or phono equalizer (purchased separately) is recommended.

For details on the connections, consult the operating instructions of the component used.

(7) Keep the stylus tip clean at all times.

Use the brush provided to remove the dirt and dust on the stylus tip.

A stylus cleaner (purchased separately) is recommended to remove stubborn dirt.

Clean the stylus tip by moving the brush from the base toward the stylus tip. When the cartridge has been removed from the arm, do not forget to attach the protector, and store the cartridge away from the amplifier and other heat sources.

How to clean the stylus tip

Be absolutely sure to move the brush in the direction in which the record rotates.

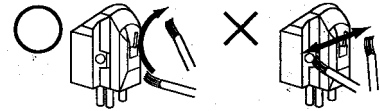

(8) When the stylus is to be replaced, replace the entire cartridge.

Take the used cartridge to your dealer.

This cartridge, or any other model which is desired among the lineup of MC cartridges sold by Audio-Technica, is available at the stylus replacement price. Once the production of this cartridge has ended, one of the MC cartridges still being marketed will be available at the stylus replacement price. Please make a note of this.

Specifications

Type :	Moving coil (MC) type
Frequency response :	15 to 50,000 Hz
Output voltage :	0.4mV (1 kHz, 5 cm/sec.)
Channel separation :	30 dB (1 kHz)
Channel balance :	0.5 dB (1 kHz)
Tracking force :	1.8 to 2.2 g (standard: 2.0 g)
Coil impedance :	12 Ω (1 kHz)
DC resistance :	12 Ω
Recommended load impedance :	Min. 100 Ω

	(when head amplifier is connected)
Coil inductance :	25μH (1 kHz)
Static compliance :	35 × 10 ⁻⁶ cm/dyne
Dynamic compliance :	18 × 10 ⁻⁶ cm/dyne (100 Hz)
Stylus :	Line contact stylus

	(curvature radius: 40 × 7μm)
Cantilever :	0.26 mm diameter solid boron
Vertical tracking angle :	23 degrees
Dimensions :	17.3(H) × 16.8(W) × 25.7(L) mm
Weight :	8.0 g

- Accessories: Nonmagnetic screwdriver (x 1), washers (x 2), protector (x 1)

Cartridge mounting screws 11 mm (x 2), 16 mm (x 2)

Nuts (x 2), brush (x 1), set of PCOCC lead wires (x 1)

(Specifications are subject to change without notice due to improvements.)

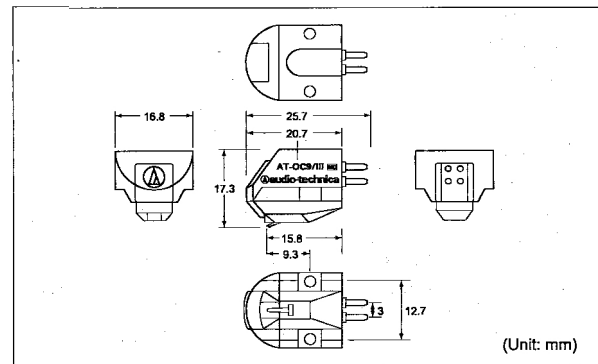

(Unit: mm)